

The Rheological Effects of Power Law Drilling Fluids on Cuttings Transportation in Non-Vertical Boreholes

Harrison, O. and Kporngor, J. A.
UMaT

Abstract

Cuttings transportation in non-vertical boreholes is necessary for oil and gas wells. Efficient cuttings removal from a well in drilling is critical for cost-effective drilling as high annular cuttings buildup often leads to high risk of stuck pipe, reduced rate of penetration and other impediments to standard drilling and completion procedures.

This study investigates how rheological parameters influence the removal of cuttings in non-vertical boreholes. It contributes to work already done to ensure efficient hole cleaning process. In this study, rheological parameters were examined. Fifteen mud samples, three annular velocities and three hole angles were considered. An excel spreadsheets program was developed and used to determine the parameters and the part they play as far as removal of cuttings from non-vertical boreholes is concerned.

Introduction

Many materials of engineering interest must be handled and transported as slurries or suspensions of insoluble particulate matter. Transportation of cuttings in non-vertical boreholes is of no exception. Almost the same thing occurs whereby the cuttings act as the solids in the drilling fluid. In spite of the many technological advances that have accompanied the drilling of non-vertical boreholes, one significant remaining challenge is effective cuttings transport, particularly in deviated wells.

The transportation of cuttings during drilling has a major influence on the economics of the drilling process. Problems that can occur as a result of inefficient hole cleaning from cuttings include reduced weight on bit, reduced rate of penetration (ROP), increase pipe sticking and inability to attain the desired reach, extra cost because of the need of special additives in the drilling fluid, extra pipe wear, transient hole blockage which can lead to lost circulation and wasted time for wiper tripping. (Kelessidis, 2004).

Hole cleaning relying on viscous fluids in laminar flow for drilling, especially when using coiled tubing, has shown to be inefficient because of the inability to rotate the string to agitate the bedded/accumulated cuttings. Alternatively, a high fluid flow to induce turbulent flow regime is more effective for hole cleaning, but difficult to achieve because of high friction pressures in the drillpipe. Therefore a bed of cuttings is almost always present in non-vertical boreholes.

Rheology which is the study of the flow and deformation of fluids is an important contributing factor to the above mentioned problems. Rheology describes the relationships between shear rate and shear stress. Pilehvari, Azar, and Sanchez state that fluid velocities should be maximized to achieve turbulent flow, and mud rheology should be optimized to enhance turbulence in inclined/horizontal sections of the well bore.

The purpose of this study is to investigate how rheological parameters influence the removal of cuttings in non-vertical boreholes.

Fluid Rheology

Rheology is the study of the flow and deformation of fluids. Deformation is a change in shape in response to an applied force, which can be tension, compression, shear, bending, or torsion. A force applied to an area is called a stress. The fluids are mainly liquids but also soft solids flowing under conditions in which they flow without deforming elastically may be included. Rheology comes from the Greek word "rheos" which means to flow. The rheological characteristics of fluid are important in evaluating its ability to perform a specific function. It describes the relationships between the shear rate and the shear stress that causes movement. The study of rheology shows how materials, particularly liquids, respond to applied stress.

Drilling fluid with adequate low end rheology will form soft or no cuttings beds when the pump is off, minimizes torque and drag while drilling, lessens the chance of becoming mechanically stuck and brings about easy logging and testing. (Q'Max Solutions Inc., 2009).

Rheological models combine developments in the fields of particle settling and rheology to provide a useful tool for the planning of hole cleaning. Various models are used to describe the shear-stress versus the shear-rate behavior of drilling fluids. The most commonly used are the Power Law, Bingham Plastic, and Herschel-Bulkley.

Theory of Cuttings Transport

The ability of a drilling fluid to transport cuttings to the surface is generally referred to as “carrying capacity”. From an engineering point of view, cuttings transport is dependent on well bore inclination, cuttings slip velocity, flow regime, rotary speed of the drill pipe, fluid rheology, fluid flow rate, rate of penetration, cuttings size and shape, wellbore geometry and other drilling parameters.

Efficient hole cleaning is especially important in drilling non-vertical boreholes since problems can be worsen due to the smaller clearances between the drilling string and the wellbore. For an inclined well, the direction of cuttings settling is vertical, but the fluid velocity has a reduced vertical component. This decreases the mud’s capability to suspend drilled cuttings. At a high angle of inclination a particle that sediments through the mud has a short distance to travel before striking the borehole wall. Once it reaches the wall, the particle has little chance to be entrained because local fluid velocities near the wall are very low and insufficient to re-entrain the particle into the flow. Consequently, the residence time of the particle in the annular space increases significantly resulting in a higher concentration of cuttings in the wellbore. This brings about formation of a cuttings bed that creates operational problems. (Sifferman and Becker, 1990).

Annular velocity, (AV) and Critical Annular Velocity (AVc)

These parameters are paramount in the hole cleaning technology as they influence the efficiency of the drilling process. The annular velocity (ft/min), can be calculated by the expression:

$$AV, (ft/min) = \frac{24.5 \times Q}{d_h^2 - d_p^2} \quad (\text{Eq. 1})$$

Fig. 4: Rheogram of Newtonian, Bingham Plastic, Power-Law and Typical Drilling Fluids.

The critical annular velocity can also be obtained by the expression;

$$AVc = (X)^{1/(2-n)} \quad (\text{Eq. 2})$$

where
$$X = \frac{81600(K)(n)^{0.387}}{(d_h - d_p)^n MW}$$

Cuttings Slip Velocity, Cuttings Net Rise Velocity and Transport Efficiency

Drilled cuttings have the tendency to fall down (slip) through the fluid medium at a velocity referred to as the **cutting slip velocity** (V_s). For the fluid to lift to the surface, the fluid annular velocity (AV) must exceed the cutting slip velocity (V_s). The relative velocity between fluid annular velocity and cutting slip velocity is known as the **cutting net rise velocity** (V_t).

The cutting slip velocity, (ft/min) is given by:

$$V_s = \frac{(DensP - MW)^{0.667} \times 175 \times DiaP}{MW^{0.333} \times \mu^{0.333}} \quad (\text{Eq. 3})$$

$$\text{where } \mu = \left(\frac{2.4AV}{d_h - d_p} \times \frac{2n+1}{3n} \right)^n \times \left(\frac{200K(d_h - d_p)}{AV} \right)$$

The cuttings net rise velocity is therefore given by:

$$V_t = AV - V_s \quad (\text{Eq. 4})$$

Cuttings transport efficiency (E_t), is simply the ratio of cuttings transport to annular velocity. It is perhaps more important than an actual cuttings transport value and it is given by:

$$E_t = \frac{V_t}{AV} \times 100 = \left(1 - \frac{V_s}{AV} \right) \times 100 = 100R_t \quad (\text{Eq. 5})$$

Axial and Radial Components of Particle Slip Velocity

The behaviour of cuttings in inclined wells is very different from that in vertical wells. In a vertical hole, slip velocity acts parallel to the axis of the hole. In inclined holes, slip velocity has two components, an axial one and a radial one. According to gravity laws, only the axial component of the slip velocity exists in the case of a vertical annulus:

$$V_s = V_{sa} \quad (\text{Eq. 6})$$

This situation changes while the annulus is inclined gradually. The component of the slip velocity appears as

$$V_{sa} = V_s \cos\theta \quad (\text{Eq. 7})$$

$$\text{and } V_{sr} = V_s \sin\theta \quad (\text{Eq. 8})$$

This situation is shown in Fig. 1

Obviously, as the angle of inclination is increased, the axial component of the slip velocity decreases, reaching zero value at the horizontal position of the annulus. At the same time, the radial component reaches a maximum value.

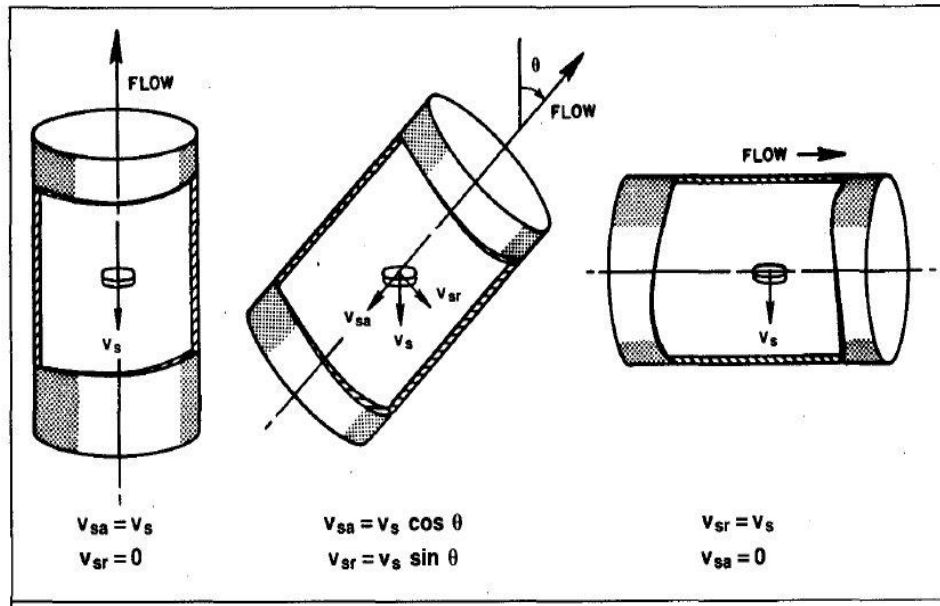

Fig. 1: Particle settling velocity in an inclined annulus (Okrajni and Azar, 1986)

Cuttings Concentration, (vol %)

Due to the slip velocity of cuttings in the annulus, the concentration of cuttings in the annulus depends upon the transport efficiency as well as the volumetric flow rate and the rate at which cuttings are generated at the bit (ROP and hole size). Experience has shown that cuttings concentration in excess of five (5) volume % can lead to a pack-off, tight hole, or stuck pipe. (Baker Hughes, 2006). When drilling in soft formations, where pipe connections in the drillstring are made as rapidly as possible, the cuttings concentration may easily exceed 5%, if ROP is uncontrolled. (Baker Hughes, 2006).

The cuttings concentration is calculated by:

$$C_a = \frac{(ROP)d_h^2}{14.71(E_t)Q} \times 100 \quad (\text{Eq. 9})$$

Discussion and Analysis of Results

The rheological parameters examined were the power law flow index, consistency index, plastic viscosity (PV), mud yield point (YP), YP/PV ratio, apparent viscosity, effective viscosity and the Fann viscometer dial readings. Power law fluid was used in this study. Three annular mud velocities were considered, (3.82, 2.86 and 1.91 ft/sec). Hole inclinations of 30°, 45° and 70° from the vertical were taken into account.

The values of the other variables used in this study are shown in Table 1 while the muds used and their parameters are shown in Table 2. An excel program was therefore developed and from it, a wide range of cuttings concentration was observed.

Inside diameter of casing or hole size (d_h)	5 in.
Outside diameter of pipe or tubing (d_p)	2 in.
Diameter of cuttings (DialP)	0.25 in.
Density of cuttings (DensP)	22 ppg
Rate of Penetration (ROP)	50 ft/hr

Table 1: Values of other variables used in the annulus cleaning study

		Dial Readings					n_a	
--	--	---------------	--	--	--	--	-------	--

Mud No.	Density (lbm/gal)	Fann Rotary Speed, rev/min (Shear Rate, seconds ⁻¹)						App. Viscosity (cp)	PV (cp)	YP (lbf/100 ft ²)	YP/PV		K _a (lbf-sec ⁿ)/ft ²
		Θ3	Θ6	Θ100	Θ200	Θ300	Θ600						
		1	8.45	1	1	8	14						
2	8.45	1	1	7	10	12	18	9	6	6	1.0	0.5396	2.1192
3	8.45	1	2	6	8	9	12	6	3	6	2.0	0.4771	2.3465
4	8.45	1	2	14	24	30	50	25	20	10	0.5	0.7386	1.5318
5	8.45	1	2	12	17	20	30	15	10	10	1.0	0.6505	1.7684
6	8.45	2	3	11	14	15	20	10	5	10	2.0	0.4375	5.0060
7	8.50	2	3	23	38	48	80	40	32	16	0.5	0.6901	3.3156
8	8.50	2	4	18	28	32	48	24	16	16	1.0	0.6021	3.8277
9	8.50	4	6	17	23	24	32	16	8	16	2.0	0.3891	10.8356
10	8.50	2	6	26	45	60	100	50	40	20	0.5	0.7386	3.0636
11	8.50	6	8	21	34	40	60	30	20	20	1.0	0.4120	15.6580
12	8.50	7	10	22	29	30	40	20	10	20	2.0	0.3160	21.3624

Table 2: Mud Parameters used for the study (Becker et al., 1991)

Effects of rheological parameters on critical annular velocity

Plots of critical annular velocity versus some of the major rheological parameters mentioned above were made from which a lot of valuable information can be deduced. For effective lift and transportation of the cuttings, the critical annular mud velocity should be greater than the settling velocity of the largest cutting. Low critical annular velocity will lead to an undesirably high concentration of cuttings in the annulus.

In Fig. 2, it can be shown that, an increase in the flow index (n) increases the critical annular velocity. The amount of cuttings concentration in the annulus will therefore be on the decrease as

the value of n increases because of the tendency of n to cause an increase in the fluid velocity in the annulus.

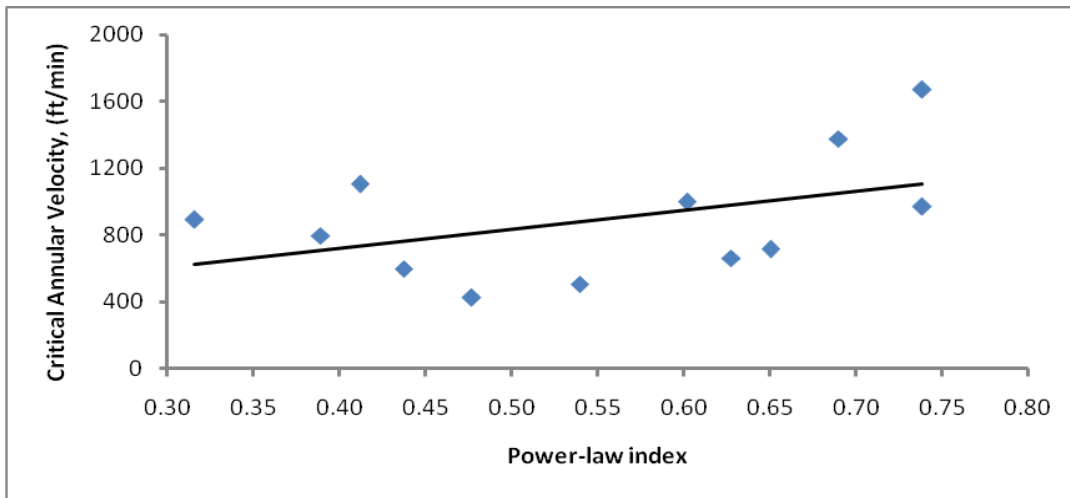

Fig. 2: Effect of power-law index on critical annular velocity

Below is Fig. 3 which also shows how the power-law consistency index influences the critical annular velocity which aids in efficient hole cleaning process. According to this study, the effect of consistency index corrected for the annulus on the critical annular velocity is minimal. Thus, the figure shows that increasing values of K increase critical annular velocity but only slightly. It can be said that the critical annular velocity is directly proportional to the consistency index.

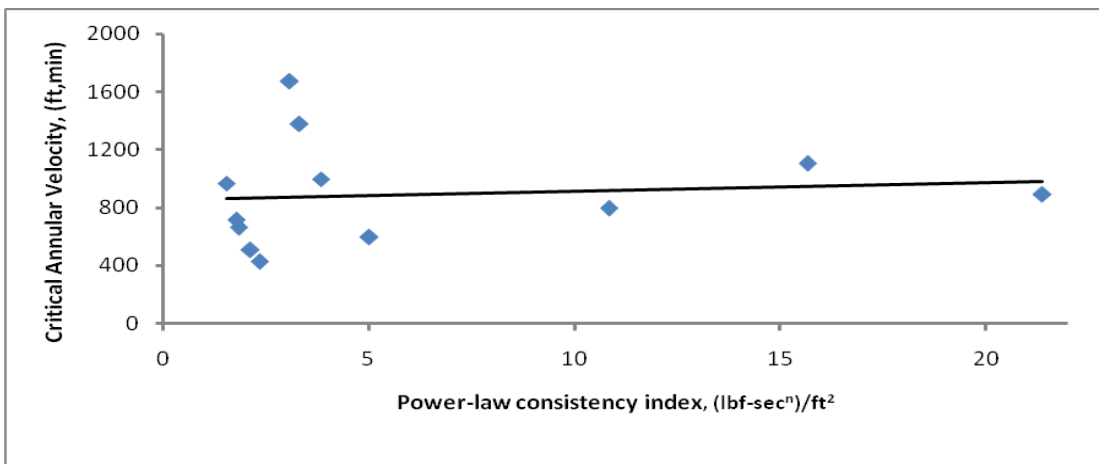

Fig. 3: Effect of power-law consistency index on critical annular velocity

Critical annular velocity is seen to increase significantly with an increase in plastic viscosity. This is depicted in Fig. 4. To ensure effective and successful cuttings removal from the annulus it

is then advisable to increase the plastic viscosity which will indirectly increase the critical annular velocity required to accomplish the hole cleaning purpose.

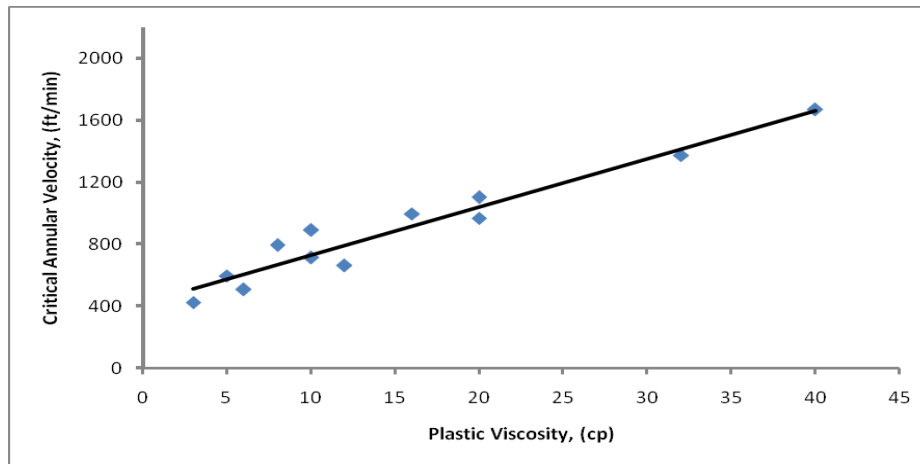

Fig. 4: Effect of plastic viscosity on critical annular velocity

A graph of critical annular velocity versus yield point can also be seen in Fig. 5. The trend of this plot is similar to that in Fig. 4. It shows a significant increase in critical annular velocity as the yield point is increased. Therefore a high yield point will ensure a good hole cleaning process.

The combined effect of yield point and plastic viscosity on the critical annular velocity was also investigated under this study. This was done by plotting a graph of YP/PV ratio against the critical annular velocity. This is shown in Fig. 6.

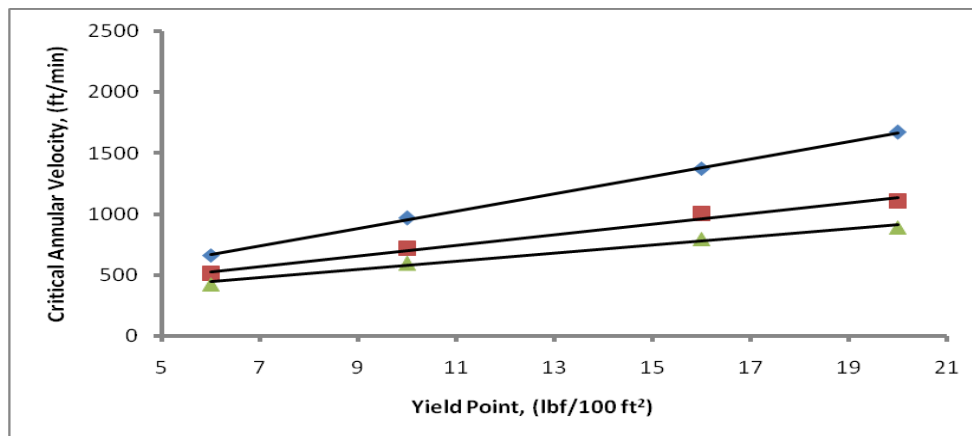

Fig. 5: Effect of yield point on critical annular velocity

As it was seen from Figures 4 and 5 that critical annular velocity increases with increase in plastic viscosity and yield point respectively, then by the combination of these information and that from Fig. 6, it can therefore be said that the PV value must be increased as well as the YP value but in a way that the critical annular velocity can bring about a good cuttings transportation.

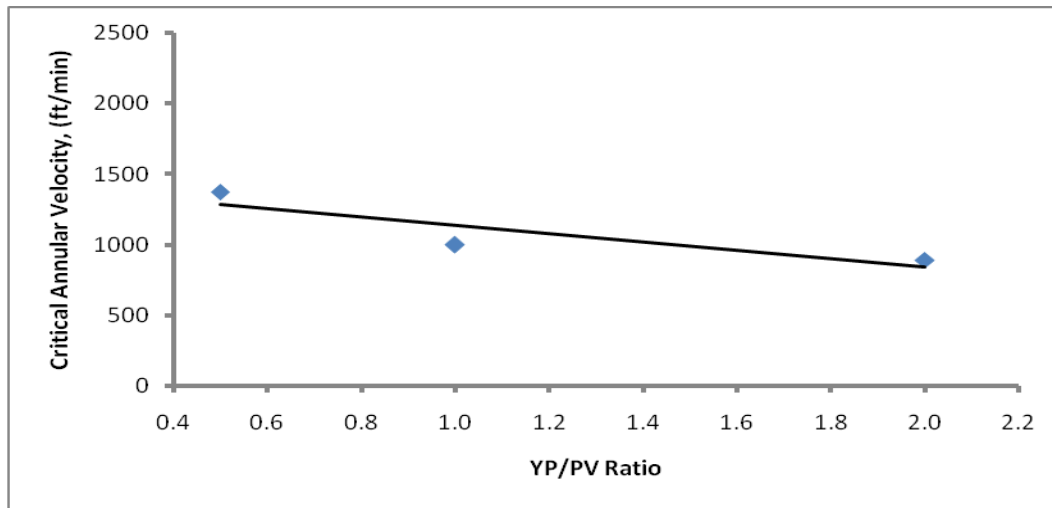

Fig. 6: Effect of YP/PV ratio on critical annular velocity

Effects of rheological parameters on cuttings concentration

In order to know the influence that rheological parameters have on the amount of cuttings generated in the annulus, various plots were again made.

Figures 7 (a) and (b) are plots of cuttings concentration versus apparent viscosity. Both plots show that, cuttings concentration declines with increasing value of apparent viscosity. Again, it was observed that, Fig. 7 (b) which has a lower annular mud velocity recorded higher values of cuttings concentration compared to Fig. 7 (a). For efficient hole cleaning process, it is then important to resort to high apparent viscosity values while maintaining a high annular mud velocity.

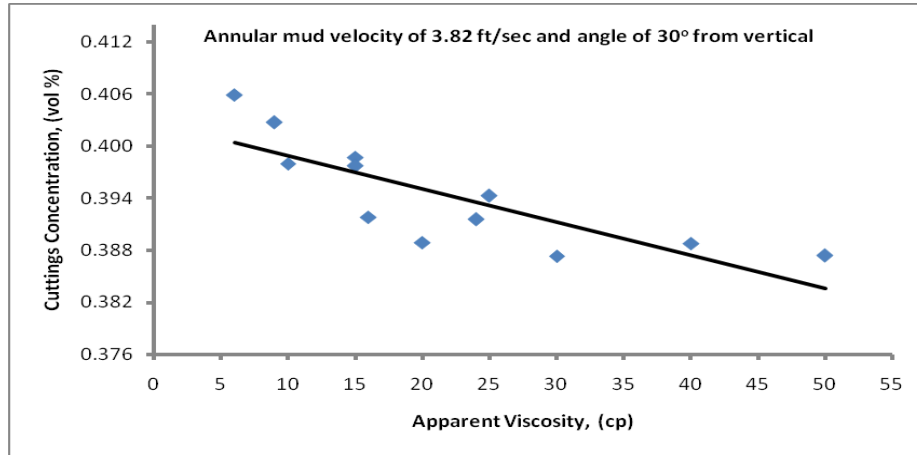

Fig. 7 (a): Annular cuttings concentration vs. Apparent viscosity for annular velocity of 3.82 ft/sec and angle of 30° from vertical

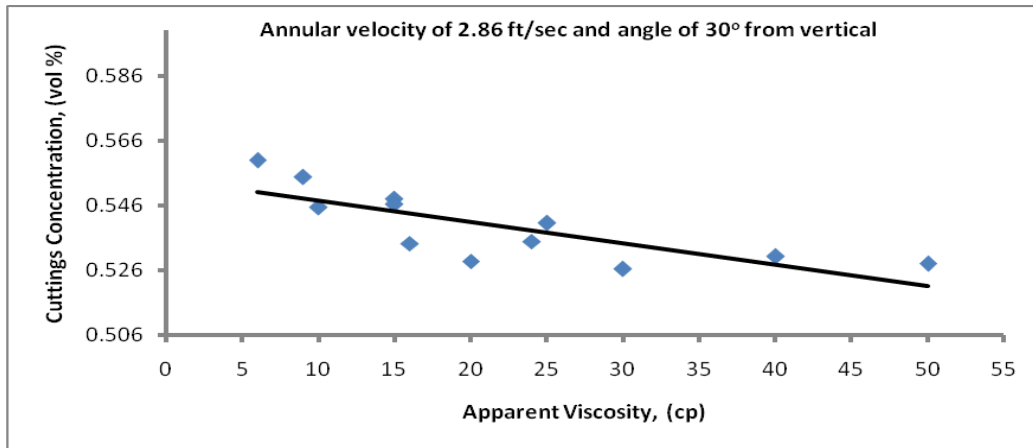

Fig. 7 (b): Annular cuttings concentration vs. Apparent viscosity for annular velocity of 2.86 ft/sec and angle of 30° from vertical

In figures 8 (a) and (b), similar trends as in Fig. 7 are shown. These figures are as a result of plot of cuttings concentration versus effective viscosity. It can be deduced from these plots that increasing effective viscosity and increasing annular mud velocity help in promoting good and efficient cuttings removal.

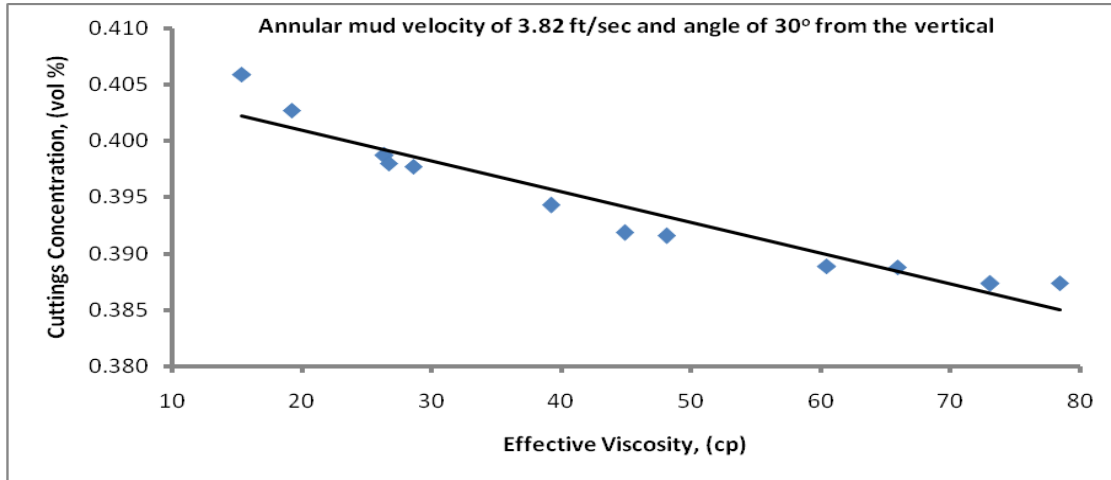

Fig. 8 (a): Annular cuttings concentration vs. Effective viscosity for annular velocity of 3.82 ft/sec and angle of 30° from vertical

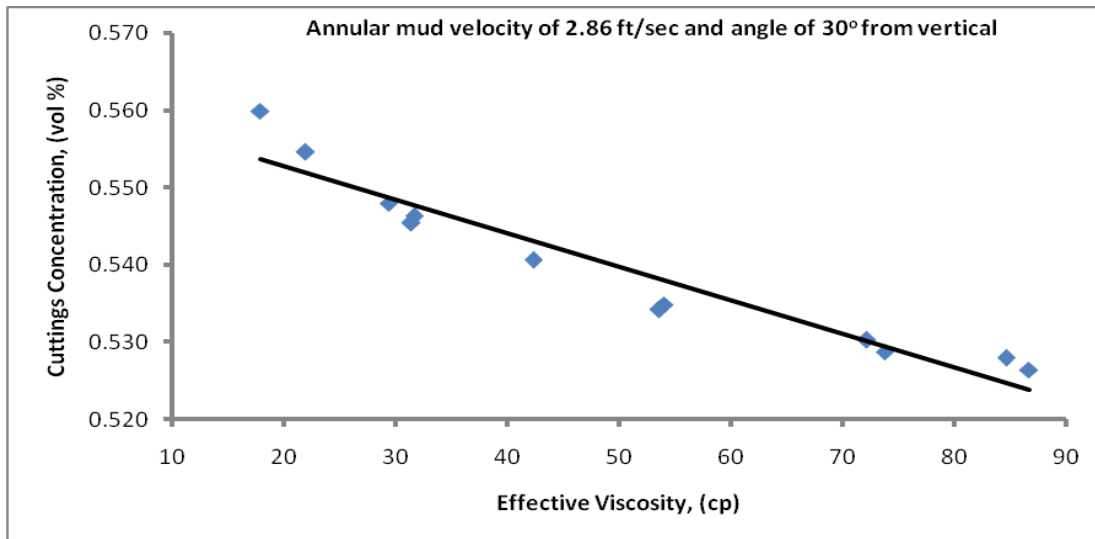

Fig. 8 (b): Annular cuttings concentration vs. Effective viscosity for annular velocity of 2.86 ft/sec and angle of 30° from vertical

In the plots that follow, the cuttings accumulation in the annulus have been plotted against the rheological parameters taken into accounts the angle of inclination of the drilled hole.

Figure 9 shows the effects of the power-law flow index on the cuttings concentration at the selected annular mud velocities for $\theta = 30^\circ$ from vertical. From this plot, it can clearly be shown

that the higher the annular mud velocity, the lower the cuttings concentration. Increasing values of the power-law flow index will also lead to an increase in cuttings concentration but only slightly. Similar trends were obtained for hole angles 45° and 70° from vertical.

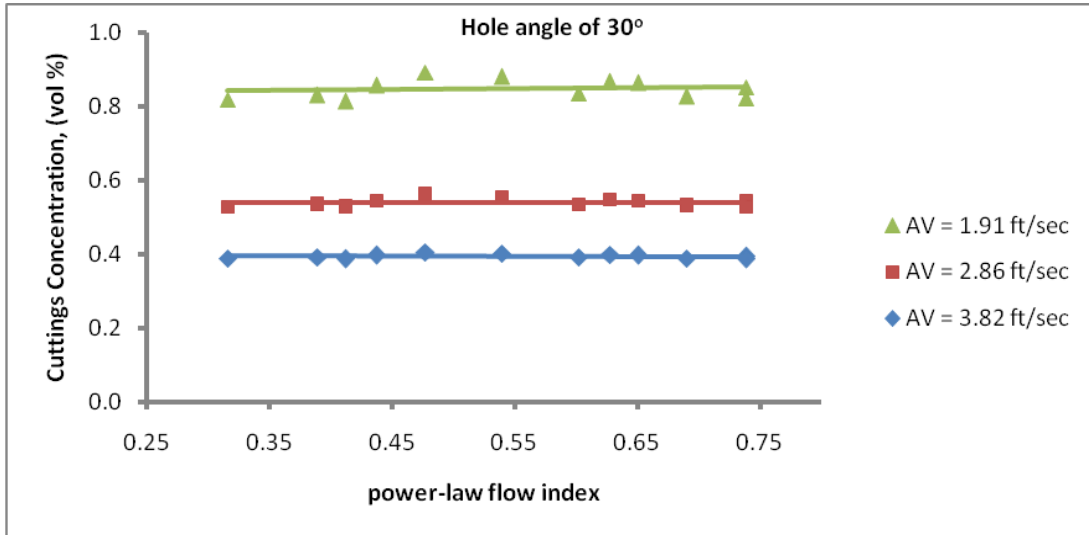

Fig. 9: Combined effect of power-law flow index on cuttings concentration ($\theta = 30^\circ$)

In addition, Figure 10 also shows how the power-law flow index affects cuttings concentration. This time, all the hole angles were considered. The plot at $\theta = 70^\circ$ from vertical gave the lowest amount of cuttings concentration followed by that at $\theta = 45^\circ$ while $\theta = 30^\circ$ gave the highest.

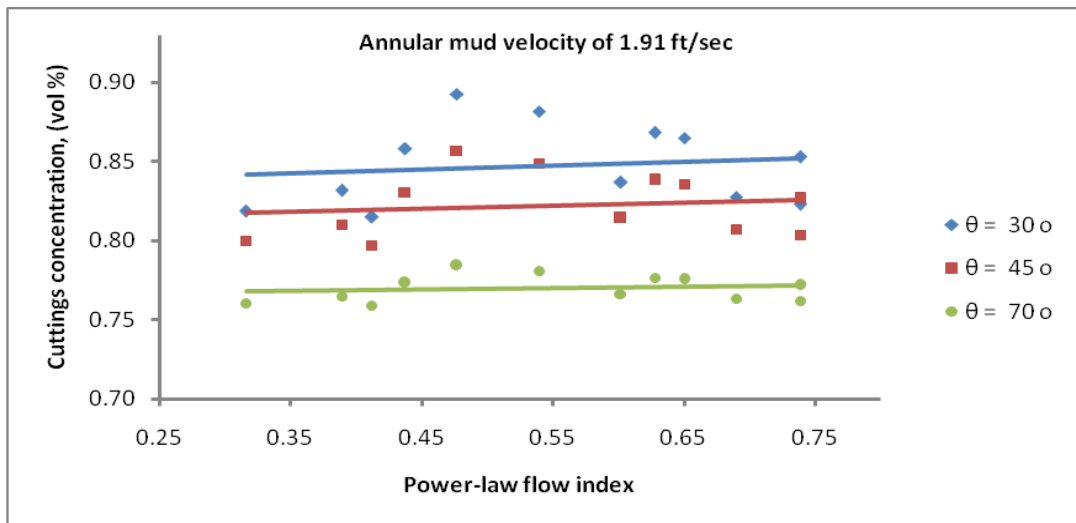

Fig. 10: Annular cuttings concentration vs. Power-law flow index for annular velocity of 1.91 ft/sec

Considering the graph of the combined effect of consistency index on cuttings concentration for hole angle of $\theta = 30^\circ$ from vertical, the cuttings concentration reduces with increasing consistency index. Also the annular mud velocity greatly influences the cuttings concentration. The higher its value the lower is the volume of cuttings generated. This is depicted in Fig. 11. Similar plots were obtained for $\theta = 45^\circ$ and $\theta = 70^\circ$

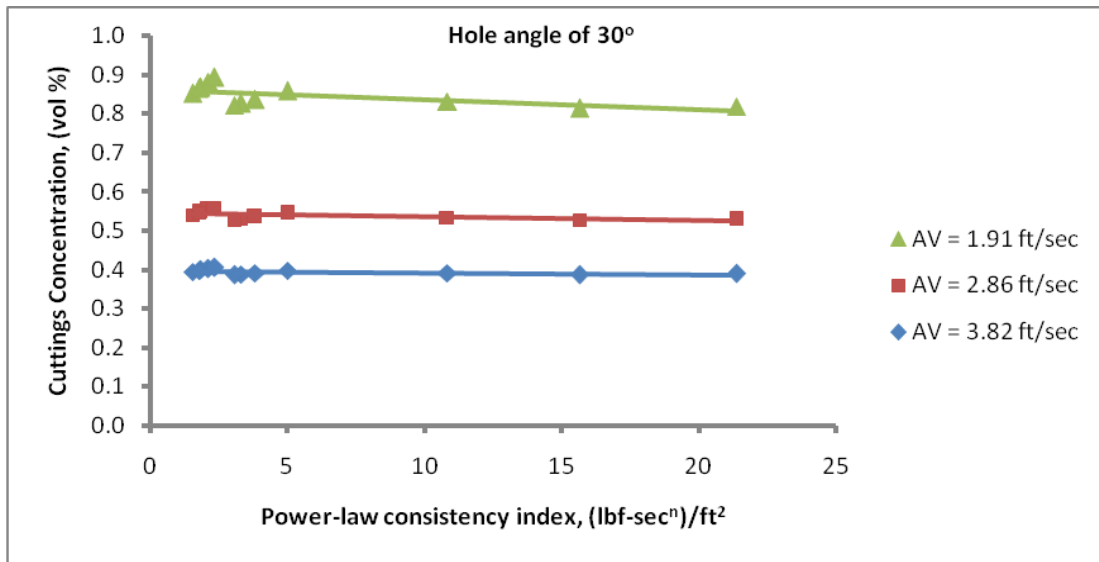

Fig. 11: Combined effect of the power-law consistency index on cuttings concentration for hole angle of 30°

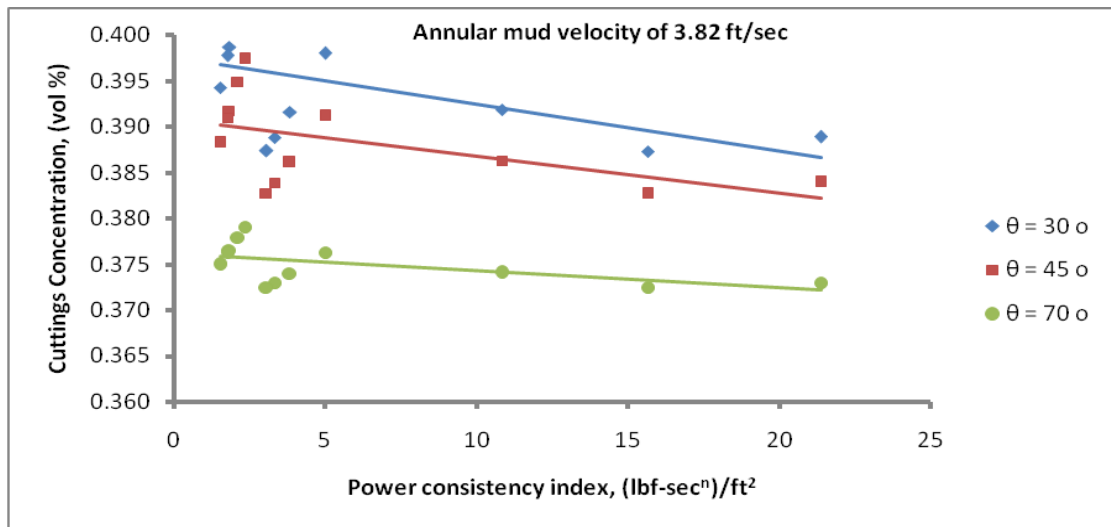

Fig. 12: Annular cuttings concentration vs. Power-law consistency index for annular velocity of 3.82 ft/sec

With regards to how the power-law consistency index affects the cuttings concentration at a given annular velocity and varying hole angles, this can be seen in Fig. 12 above. The cuttings concentration again on this round decreases as the consistency index (K_a) increases no matter the angle of inclination. An increasing value of K_a is therefore required to ensure successful cuttings transportation.

Figure 13 also shows the effect of plastic viscosity on the cuttings concentration. In this plot, the cuttings concentration declines as the plastic viscosity increases. By the combination of information obtained from this plot and that from Fig. 4, it is obvious that an increasing critical annular velocity together with increasing plastic viscosity will bring about an excellent hole cleaning.

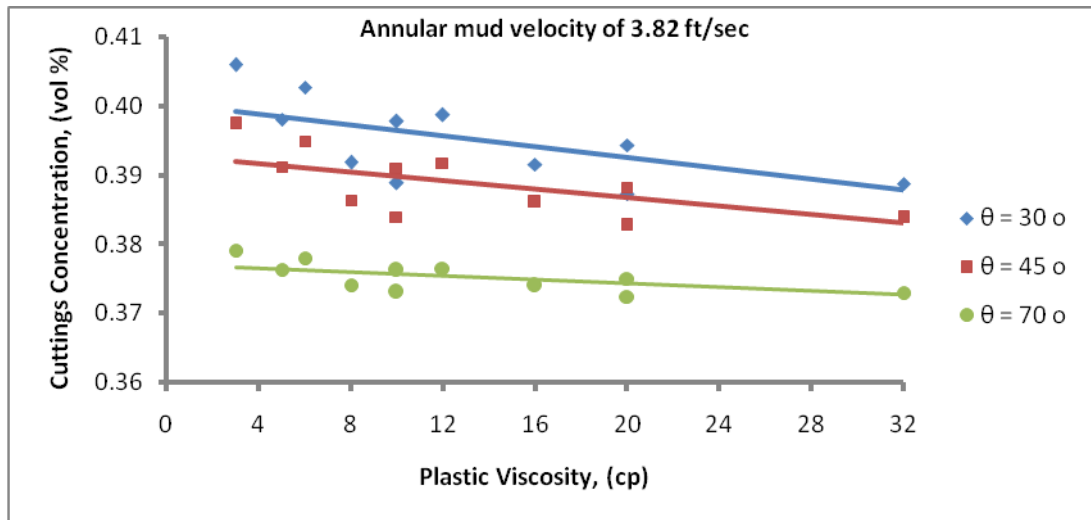

Fig. 13: Annular cuttings concentration vs. Plastic viscosity for annular velocity of 3.82 ft/sec

The effect of yield point (YP) on the cuttings concentration (C_a) was also investigated. Fig. 14 shows how C_a changes with YP at different hole angles. It is clear to deduce from this plot that higher values of YP will be an advantage as it will lead to a decrease in the amount of cuttings in the annulus thereby enhancing efficient hole cleaning.

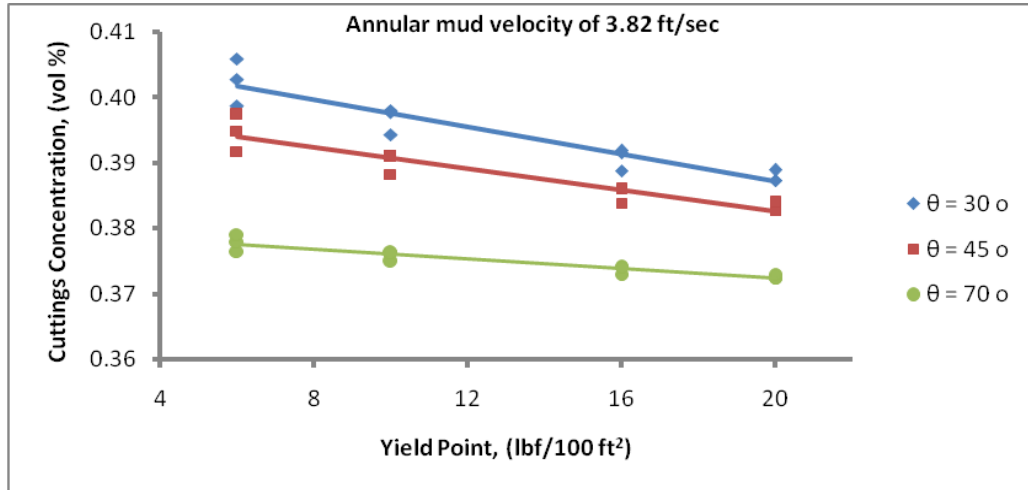

Fig. 14: Annular cuttings concentration vs. Yield point for annular velocity of 3.82 ft/sec

The combined effect of both yield point (YP) and plastic viscosity (PV) on the amount of cuttings concentration was also investigated in this study. Relatively high plastic viscosities considerably reduce the YP/PV ratio. From the plots of cuttings concentration versus YP/PV ratio shown in Figure 15, it can be shown that the higher the YP/PV ratio, the higher will be the cuttings concentration and vice versa. This is true for all the angle of inclinations considered in this study. Because of the influence that PV has on YP/PV ratio, the PV should also increase with respect to YP so as to reduce the accumulation of cuttings in the annulus. The YP/PV ratio should be low.

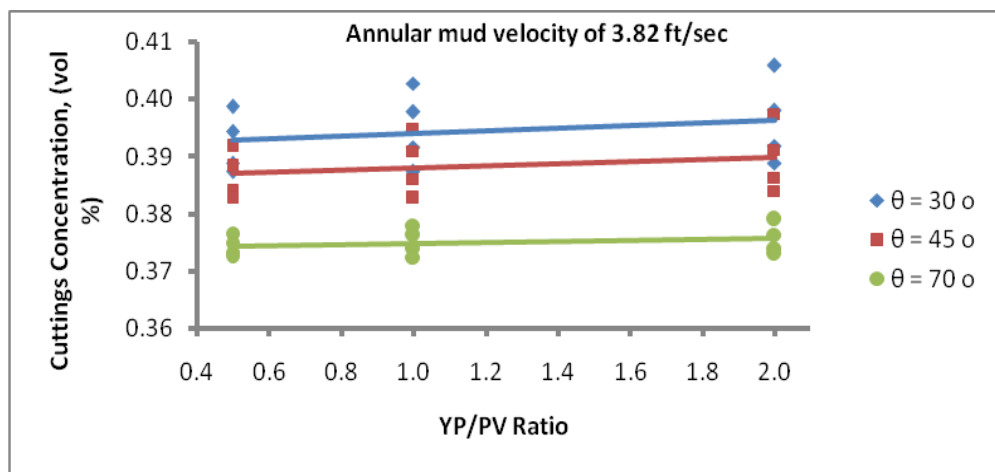

Fig. 15 Annular cuttings concentration vs. YP/PV ratio for annular velocity of 3.82 ft/sec

In Fig. 16 below, we have plots of cuttings concentration versus hole inclination. From these plots, it can be deduced that, the cuttings concentration generated is highest at 30°, followed by at 45° and decreases as the angle increases. In this study, mud 1 and 12 were used to illustrate this point and similar trends were obtained for the different annular mud velocities selected. Higher flow rates will then be needed for lower hole angles in the range of 30° – 45°.

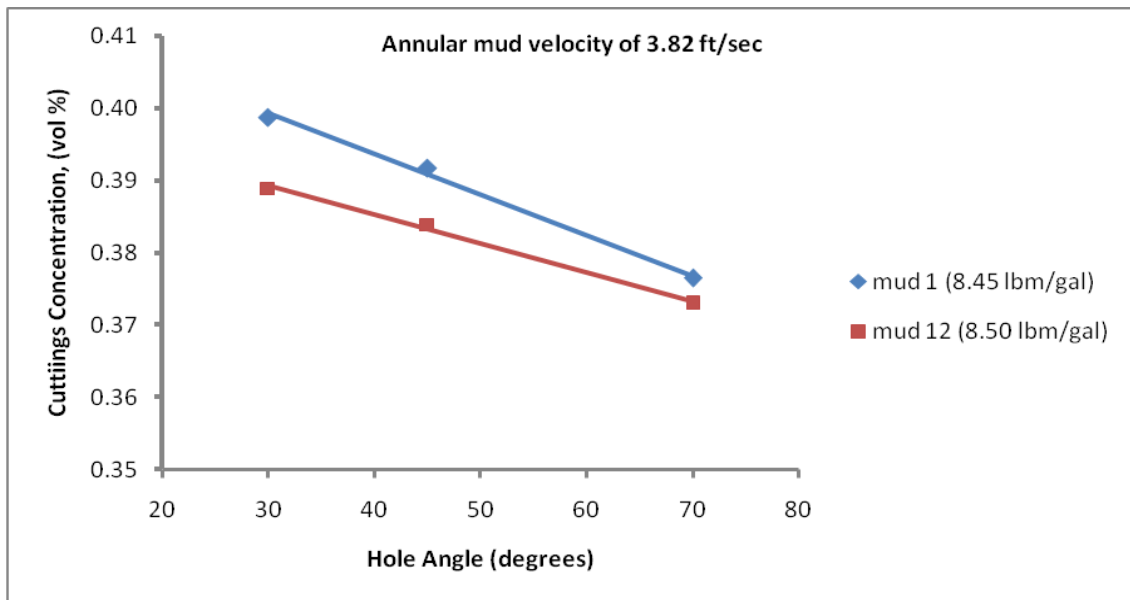

Fig. 16: Cuttings concentration vs. Hole angle for annular velocity of 3.82 ft/sec

Summary

From this study, it can be deduced that the rheological parameters such as flow index, consistency index, yield point, plastic viscosity, and YP/PV ratio have tremendous impact on the transportation of cuttings. Therefore in order to ensure efficient cuttings transportation, each rheological parameter is equally important and should be considered. It has been observed that, an increase in both the apparent and effective viscosities helps in better sweep of the cuttings, the power law flow index should also not be very high while the power law consistency index should be increased. The yield point and plastic viscosity values should all be high but done in such a way that they will result in low YP/PV ratios.

Again, whenever there is cuttings transport problem, flow rate should be increased to its limiting value for all ranges of inclinations, particularly in the range of higher angles. But when there is the occurrence of sliding-down effect of the cuttings during drilling, then this becomes critical for lower angles (30° - 45°).

Conclusions

The following conclusions were reached from this study:

1. In the study and assessment of drilling-fluid cuttings transport in non-vertical boreholes, the annular cuttings concentration (vol. %) should be considered first. Its value gives the indication of which rheological parameter to manipulate to bring about a successful cuttings removal.
2. For efficient hole cleaning process, the power-law flow index, consistency index, yield point, plastic viscosity, and YP/PV ratio should all be considered and used in the evaluation and assessment process.
3. In laminar flow, the annular cuttings concentration is lower for higher YP/PV ratios. This is true for the entire range of hole inclinations investigated in this study.
4. In laminar flow, increasing values of mud yield value result in decreasing the annular cuttings concentration. The same situation applies to increasing plastic viscosity.
5. Very high cuttings concentrations were recorded at hole inclination in the range of 30° to 45°. This normally occurs when the annular flow rates are relatively low (0 – 90 gpm).
6. In laminar flow, the effects of mud yield value and YP/PV ratio are more pronounced for lower annular mud velocities. Thus at these velocities, higher annular cuttings concentrations were recorded.
7. The effect of mud flow rate has great influence during hole cleaning in non-vertical boreholes. Higher flow rates increases the critical annular velocity which in turn brings about decreasing cuttings concentration.

Nomenclature

- AV annular velocity, ft/min
AVc critical annular velocity, ft/min

C_a	annular cuttings concentration, vol %
D_{ensP}	cutting density, ppg
D_{iaP}	cutting diameter, in.
d_h	inside diameter of casing or hole size, in.
d_p	outside diameter of pipe, tubing or collar, in.
E_t	cuttings transport efficiency, %
K	power law consistency index, lbf-sec ⁿ /ft ²
MW	mud weight, ppg
n	power-law flow index, dimensionless
PV	plastic viscosity, cp
Q	flow rate, gal/min
R_t	cuttings transport ratio
V_s	cuttings slip velocity, ft/min
V_{sa}	axial component of particle slip velocity, ft/min
V_{sr}	radial component of particle slip velocity, ft/min
V_t	cutting net rise velocity
YP	yield point, lbf/100 ft ²
τ	shear stress, lbf/ft ²
γ	shear rate
θ	hole angle

Acknowledgments

Our deepest and sincere gratitude go to Prof. Godwin Chukwu for his tremendous support and invaluable advice towards the completion of this work.

To our most wonderful mum, Adwoa Tiwaa Badu, lovely brother, Pr. Alexander Marfoh, and bosom friend, Alberta Asantewaa for supporting and praying for us every step of the way. We will forever be grateful for your love, support and guidance. May the good Lord richly bless you.

References

1. ASME, (2005), "Drilling Fluids Processing Handbook," Gulf Professional Publishing Publications, US, pp. 32-37.

2. Azar, J. J. and Sanchez, R. A., (1997), "Important Issues in Cuttings Transport for Drilling Directional Wells," paper SPE 39020 presented at the 1997 SPE Latin American and Caribbean Petroleum Engineering Conference and Exhibition, Rio de Janeiro, 30th August – 3rd September.
3. Anon, (2006), Baker Hughes Drilling Fluid Reference Manual.
4. Becker, T. E., Azar, J. J., and Okrajni, S. S., (1991), "Correlations of Mud Rheological Properties With Cuttings Transport Performance in Directional Drilling," pp. 16 – 24.
5. Bharucha, V. C., (2004), "Rheological Study of Hydroxypropyl Guar (HPG) Slurries," mpge.ou.edu, Norman, Oklahoma, , pp. 11-16.
6. Carriere et al., (2003), "US Patent," Patent No.:US 6,502,641 B1.
7. Darley, H. C. H. and Gray, G. R., (1988), "Composition and Properties of drilling and Completion Fluids," 5th Edition, Gulf Publishing Company, Houston, TX., pp. 184 – 276.
8. Kelessidis, V. C. and Bandelis G. E., (2004), "Flow Patterns and Minimum Suspension Velocity for Efficient Cuttings Transport in Horizontal and Deviated Wells in Coiled-Tubing Drilling", paper SPE 81746 first presented at the 2003 SPE/ICoTA Coiled Tubing Conference, Houston, 8–9 April, pp. 213-214.
9. Kenny, P., Sunde,E. and Hemphill,T., (1996), "Hole Cleaning Modeling: What's 'n'got to do with it?", IADC/SPE 35099 presented at the IADC/SPE Drilling Conference, New Orleans, La, March 12-15.
10. Lamar et al., (1998), "Coiled Tubing Drilling on the Alaskan NorthSlope," Summer, www.slb.com.
11. Lapeyrouse, N. J., (2002), "Formulas and Calculations for Drilling, Production and Workover," 2nd Edition, Gulf Professional Publishing Publications, US.
12. Leising et al., (1998), "Cuttings Transport Problems and Solutions in Coiled Tubing Drilling," paper IADC/SPE 39300 presented at the 1998 IADC/SPE Drilling Conference held in Dallas, pp. 86-89.
13. Anon, (1995),: "Project to Develop and Evaluate Slim-Hole and Coiled-Tubing Technology," Maurer Engineering Inc., Houston, Texas, 5-3 pp., 5-6pp.
14. Okrajni, S. S. and Azar, J. J., (1986), "The Effect of Mud Rheology on Annular

Hole Cleaning in Directional Wells," *SPEDC* (August, 1986), pp. 297-308.

15. Patrick et al., (1996), "Hole Cleaning Modelling: What's 'n' Got To Do With It?," paper IADC/SPE 35099 presented at the 1996 IAOC/SPE Drilling Conference held in New Orleans, Louisiana, pp. 480-481.

16. Pilehvari, A. A. and Azar, J. J., (1999), "State-of-the-Art Cuttings Transport in Horizontal Wellbores," *SPEDC* (September, 1999), 196 pp.

17. Power, D., (2009), "Hole Cleaning: Challenges and Solutions", ocw.kfupm.edu.sa, pp. 1- 4.

18. Anon, (2009), "Hole Cleaning in Deviated Wells – Rheological Require," Q'Max Solutions Inc., www.qmaxsolutions.com.

19. Sifferman, T. R., & Becker, T. E., (1990), "Hole cleaning in full-scale inclined wellbores," SPE paper 20422, Presented SPE Annual Conference, New Orleans, 23–26 September, 1990, pp. 115 –120.

20. Tomren, P. H., Iyoho, A. W., and Azar, J. J., (1985), "Experimental Study of Cuttings Transport in Directional Wells," *SPEDE* (Feb. 1986), pp. 43 – 56

21. Williams et al., (2001), "Sound Coiled-Tubing Drilling Practices," Maurer Technology Inc, Houston, Texas pp. 6-7.